

# UNDER COUNTER DRAWER SERIES

## WITH INVERTER SYSTEM



**Introducing our Under Counter Refrigerator Drawer Series with Inverter Compressor System -** combines efficient cooling with ample prep space on top, it keeps ingredients cool and easily accessible, making it the perfect fit for efficient kitchen operations. Engineered for efficiency, safety, and durability. Enjoy superior energy savings, rapid cooling, and optimized performance.



Features & Configurations	03-04
Specifications	05-06
Inverter Compressor System	07-08

# FEATURES & CONFIGURATIONS

- No welding and polishing on exterior surface of unit
- 43°C ambient temperature, can be used in the hottest places
- Monoblock refrigeration system, easy to take off for repairing and cleaning
- Exterior of AISI 304 stainless steel, back of galvanized metal plate
- Interior of AISI 304 stainless steel, High-density insulation, CFCs free, 60mm of thickness, 40Kg/M<sup>3</sup>
- High-speed fan motor ensures the cooled air is blown to anywhere inside
- Digital thermostat with temperature display, precisely set temperature for foods
- Defrosting system by Time and Temperature automatically
- Heated door frame to avoid water condensation (only for freezer)
- Draining system inside for defrosting water
- Self-closing door, changeable for drawer kits
- Door gasket is easy to take off for cleaning and replacement
- Wide round edges and corners for cleaning
- Shelf size: 530x325mm, suitable for GN 1/1 container
- Adjustable feet, up to 200mm

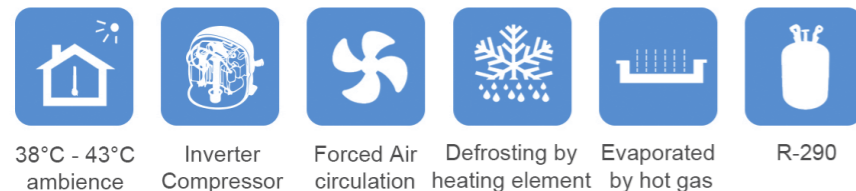

	<p><b>Inverter Compressor</b> We use a high-quality compressor with inverter technology, offering variable speed for precise temperature control and improved energy efficiency</p>		<p><b>Digital Controller</b> Precisely control and display the temperature of food based on user demand.</p>
<p><b>Extra-thick Insulation</b> 60mm thickness of insulation Better heat preservation to reduce energy consumption.</p>		<p><b>R290 Refrigerant</b> The environment-friendly R290 Refrigerant is widely used to reduce pollution.</p>	
	<p><b>Evaporator Fan</b> High speed fan motor ensures the cool air to blow to anywhere inside</p>		
<p><b>Built-in Copper Evaporator</b></p>		<p><b>American Style Handel Optional</b></p>	<p><b>Round Edge and Corner</b> Food residual and water can be easily cleaned to reduce bacteria and guarantee the safety of food.</p>
	<p><b>Adjustable Bullet Feet</b> Range 150-200mm.</p>	<p><b>Drawer Kits 1/2x200 and 1/3x150</b> Flexible and practical exchange of drawer kits and doors. It is optional.</p>	
	<p><b>Shelf and Guide</b> The height of shelves is adjustable due to the size of stored products.</p>		<p><b>Door Handle with End Cover</b> Strong and Practical Design Exchange for Right and Left hand.</p>



DN-IAWRD-12 / DN-IAWFD-12



DN-IAWRD-15 / DN-IAWFD-15



DN-IAWRD-18 / DN-IAWFD-18

Model No	DN-IAWRD-12	DN-IAWFD-12	DN-IAWRD-15	DN-IAWFD-15	DN-IAWRD-18	DN-IAWFD-18
Net Volume(L)	260L		380L		420L	
External Dimension (W x D x H mm)	1200 x 750 x 850 mm		1500 x 750 x 850 mm		1800 x 750 x 850 mm	
Cooling Type	Ventilated		Ventilated		Ventilated	
Defrosting Type	Automatic		Automatic		Automatic	
Temperature Range (°C)	+8°C ~ 0°C	-3°C ~ -20°C	+8°C ~ 0°C	-3°C ~ -20°C	+8°C ~ 0°C	-3°C ~ -20°C
Ambient Temperature (°C)	43T	43T	43T	43T	43T	43T
Refrigerant	R-290	R-290	R-290	R-290	R-290	R-290
Voltage / Frequency	220V / 50-60 Hz		220V / 50-60 Hz		220V / 50-60 Hz	
Rated Power / Current	259W / 1.3A		259W / 1.3A		259W / 1.3A	
Phase	Single Phase		Single Phase		Single Phase	
Compressor Model	VEMT406U		VEMT406U		VEMT406U	
Door / Drawer	1 Door / 2 Drawer		5 Drawer		6 Drawer	
Type	Chiller	Freezer	Chiller	Freezer	Chiller	Freezer

Warranty: One-year parts & labor for entire unit, 2<sup>nd</sup> year on compressor only, excluding doors & exterior damages.

**Main Component**

**EMBRACO COMPRESSOR (Inverter) Series**

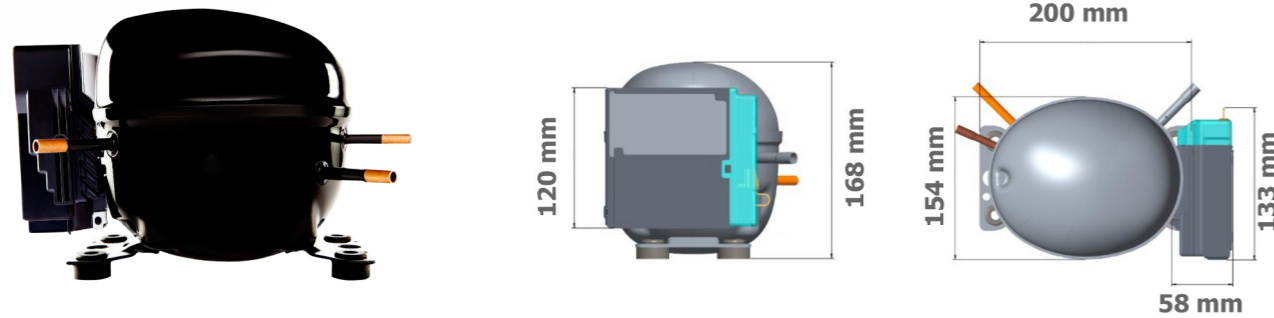

Embraco variable speed compressors are a solution for residential and commercial applications which demand fast cooling, low energy consumption, operate with a low starting voltage and with a wide operating range, low noise and vibration levels. The variable speed compressor associated with an inverter allows the compressor to run in different RPM, delivering the cooling capacity needed according to the thermal load.

**FEATURES**

- **Efficiency:** Higher EER on R290 for commercial applications at variable speed
- **Wide Voltage Range:** Guarantee for the equipment to run even with voltage fluctuation
- **Environmentally Friendly:** Uses R290 natural refrigerant with no impact on the ozone layer (GWP: 3)
- **Lower Noise & Less Vibrations:** Consistent noise level reduction
- **Longer Expected Lifespan:** Softer startup, lower stress on mechanical and electrical parts

Model No	VENT406U	VEHT409U	VEHU413U
Nominal Voltage (V)	115-240V	115-240V / 220-240V	115-240V / 220-240V
Frequency (Hz)	50-60Hz		
Disp (CC)	6.36	9.04	12.74
Refrigerant	R-290		
Inverter - Power Input	400W DV	550W DV / 1000W PFC	1000W DV / 1000W PFC
Operating Temperature	+0°C ~ -40°C		
Speed Range (RPM)	1600 to 4500		
Cap Range - Cooling Capacity	155 - 445	228 - 675	343 - 939
Max Coefficient of Performance (W / W)	1.72	1.79	1.71

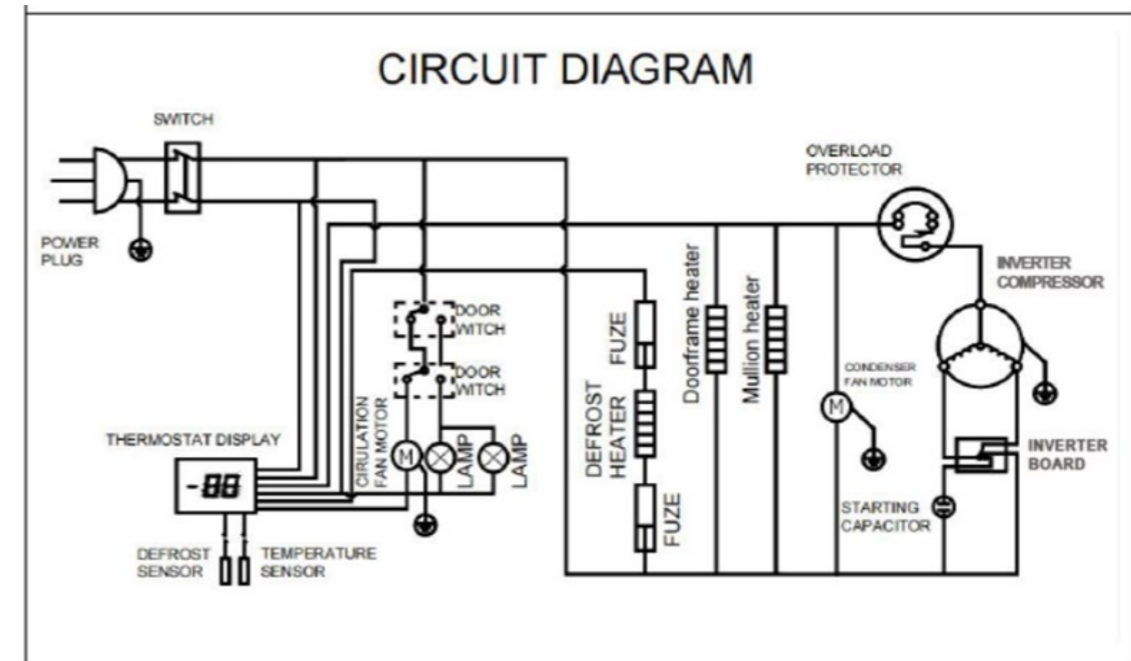

**L/MBP (Low/Medium Back Pressure) Compressor Operating Envelope**

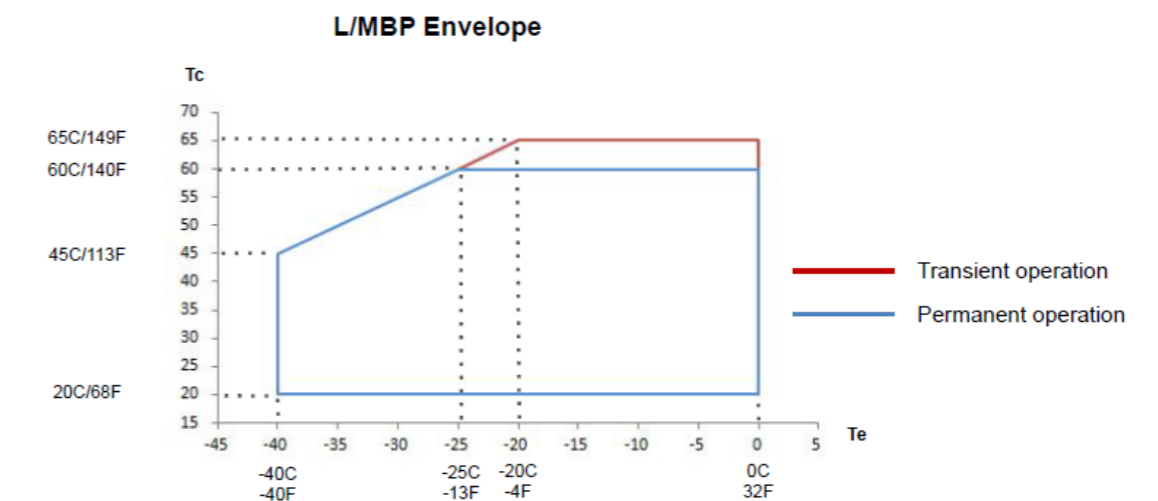

**Insights:**

- The condensing temperature can go up to 60°C (140°F) in continuous operation but can spike up to 65°C (149°F) transiently.
- The evaporating temperature can drop as low as -35°C for safe continuous use, with the compressor capable of handling even lower temperatures (-40°C), but only temporarily.
- The graph shows the compressor's performance limitations and indicates where it performs best without risking damage due to excessive pressure or temperature extremes.

**DANENG KITCHEN EQUIPMENT PTE LTD**  
Commercial Kitchen Equipment Specialist in Singapore

Sales: +65 6747 0435 / Email: sales@daneng.com.sg  
Office: 3 Kaki Bukit Industrial Terrace, Singapore 416091

www.daneng.com.sg

